

RevNo	Revision note	Date	Signature	Checked
-------	---------------	------	-----------	---------

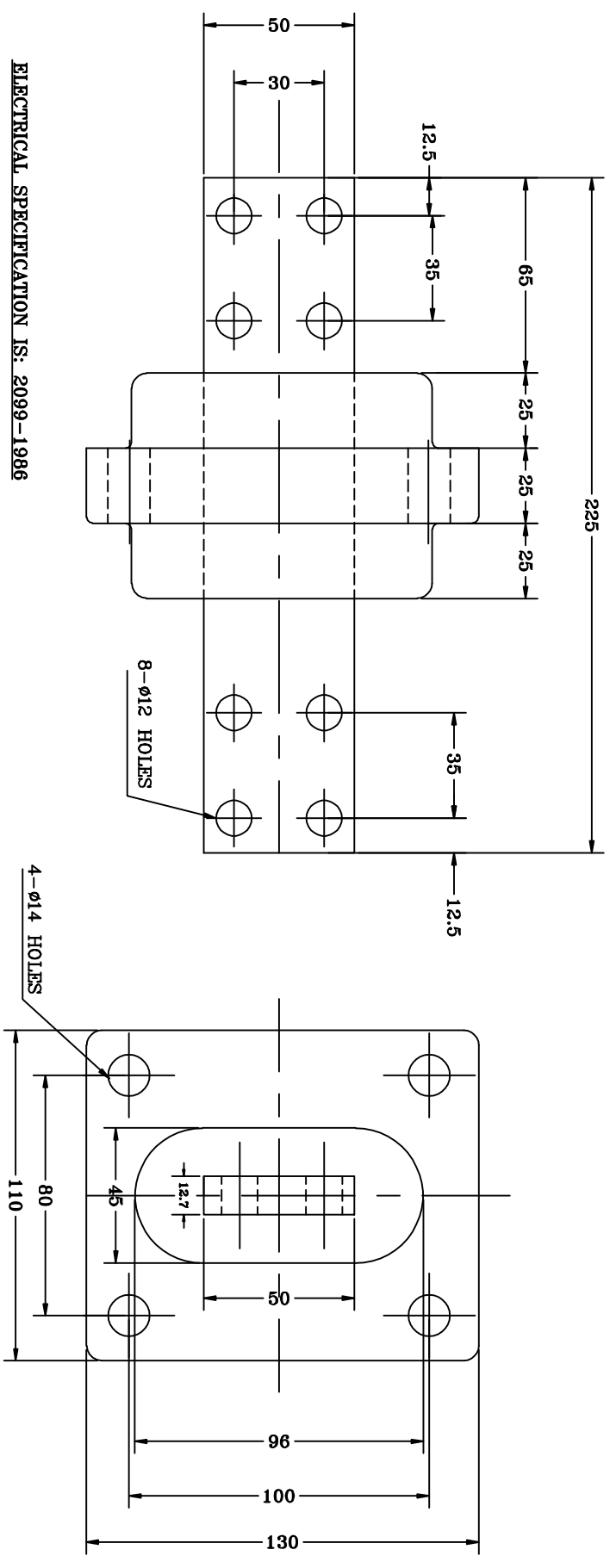

- ELECTRICAL SPECIFICATION IS: 2099-1986**
- 1 RATED VOLTAGE.....1.1kv
 - 2 DRY POWER FREQUENCY WITHSTAND VOLTAGE TEST (ONE MINUTE)...5 kv
 - 3 MINIMUM CURRENT CAPACITY.....1000 Amps.
- NOTES:-**
- 1 END COPPER PALM WILL BE ELECTRONNED 12 TO 15 MICRONS.
 - 2 ELECTOLYTIC COPPER WITH HIGH ELECTRICAL CONDUCTIVITY.
 - 3 COLOUR BRICK RED.
 - 4 ALL DIMENSION ARE IN MM.

01	1.1 kv, 1000A	DISCRIPPTON		TYPE	01
		EPOXY RESINE CAST BUSHING		THIRD ANGLE	
		ITEM CODE: FF0108		MANUFACTURER	
				Fibre & Fibre Glass Products	
				250/7, MAGAZINE HOUSE	
				G.I.D.C. MAKARPURA,	
				VADODARA- 390010	
		DRAWING NO.:		SIGN	
		FRGP/051/11-12		KINJAL	
				AP	
				DATE	
				29/04/11	
		Sheet Edition		REV	
		1/1		0	
				0	

A B C D E F

1 2 3 4

1 2 3 4