

Signature Checked

Date

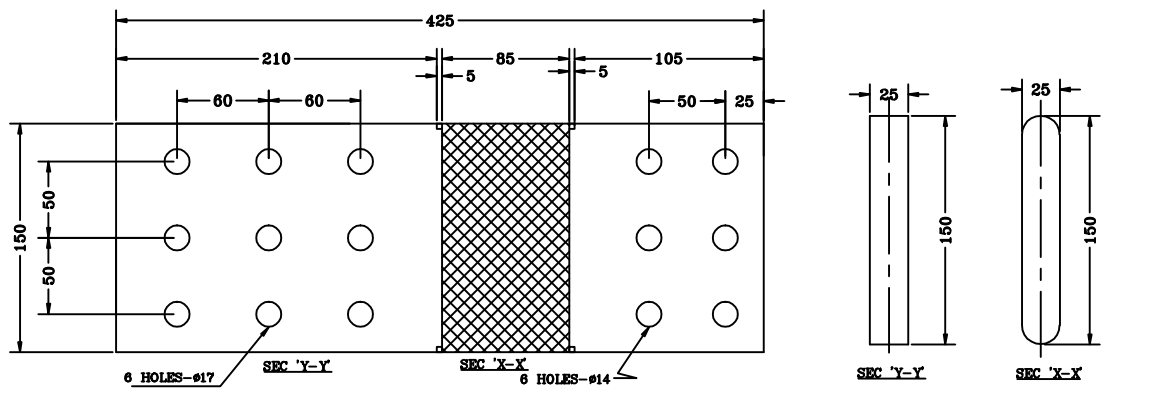

Revision note:

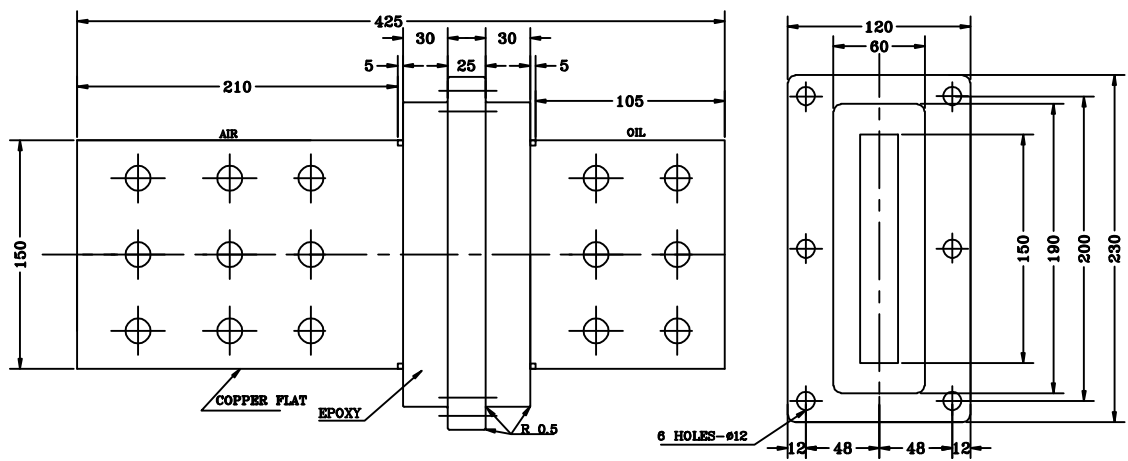

NOTE:

- 1 KNURLING/SHOT BLASTING/ANY SUITABLE SURFACE TREATMENT TO ENSURE LEAKPROOF JOINT BETWEEN COPPER FLAT AND EPOXY.
- 2 COPPER FLATE SURFACE SHOULD BE FLAT AND SMOOTH FOR ELECTRICAL CONTACTS.
- 3 TIN PLATE ENTIRE COPPER FLAT(ELECTRO TINNING)
- 4 COPPER FLAT SHOULD BE DECREASED BEFORE MOLDINGS.
- 5 EPOXY CAST ASSEMBLY SHOULD BE LEAK 90°C IN TRANSFORMER OIL TO IS : 1983 AT 1KG/SQ.Cm.

NOTE: ALL DIMENSION ARE IN mm.

01	1.1 kv ,5000A						
TYPE	DISCRIPTION						
<p>THIRD ANGLE</p>	EPOXY RESINE CAST BUSHING			SIGN	DATE		
				DRN.	TANVI	08.04.10	
	ITEM CODE: FF0095			CHD.	AP	-	
			APPD.	-	-		
	MANUFACTURER Fibre & Fibre Glass Products 250/7, MAGAZINE HOUSE G.I.D.C. MAKARPURA, VADODARA- 390010		DRAWING NO.:		Sheet	Edition	REV
			FFGP-037/10-11		1/1	0	0