

Revision note

Date

Signature

Checked

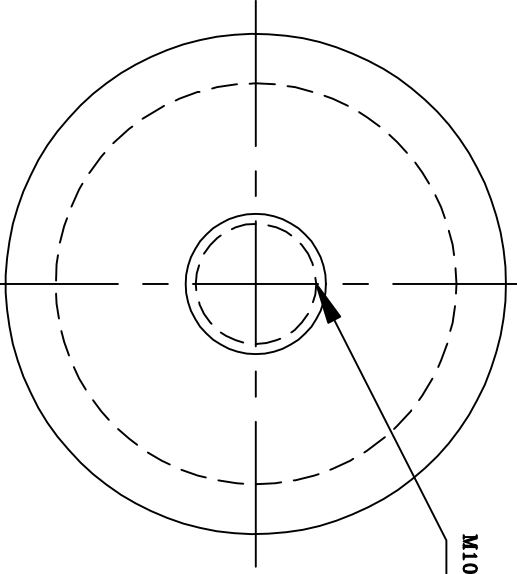
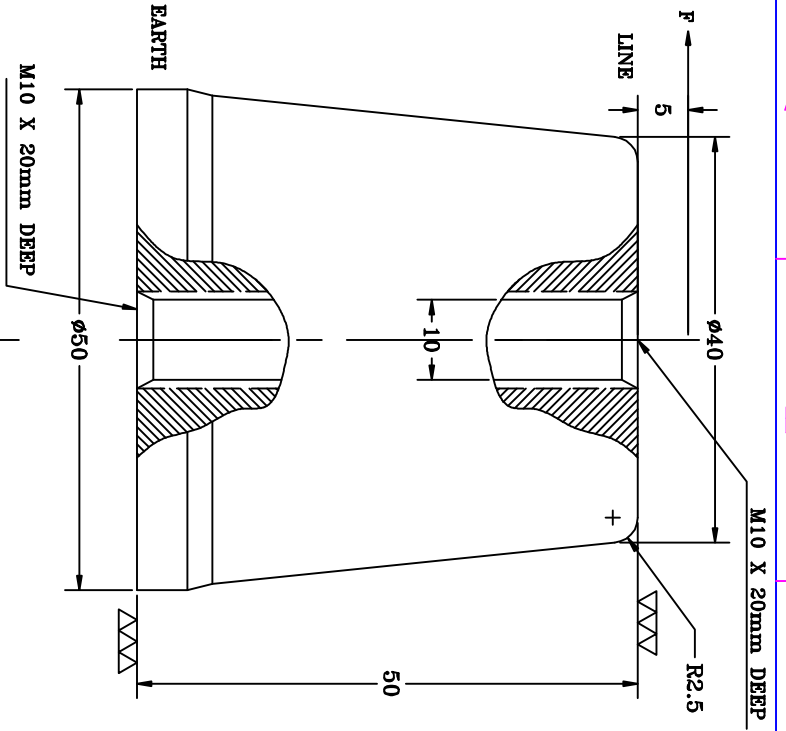



MECHANICAL SPECIFICATION IS: 9431-1979

- 1 TENSILE FAILING LOAD.....1500Kg
- 2 COMPRESSSION FAILING LOAD.....4000Kg
- 3 CANTILEVER FAILINGS LOAD.....450Kg

ELECTRICAL SPECIFICATION IS: 9431-1979

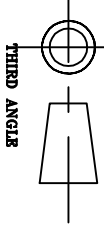
- 1 RATED VOLTAGE.....1.1kv
 - 2 DRY POWER FREQUENCY WITHSTAND VOLTAGE TES..10kv
 - 3 MINIMUM CREEPAGE DISTANCE.....52mm
- OTHERS**
- 1 COLOUR BRICK RED.
 - 2 ALL DIMENSION ARE IN MM.

| | | | | | | | |
|--|------------------------------------|---|-------|--------------------------------|--------------|------------------------|------|
| 02 | BRASS INSERTS | DISCRIPTION | 1.2kv | EPOXY RESINE CAST INSULATOR | DRAWING NO.: | SIGN | DATE |
| 01 | M.S INSERT WITH WHITE ZINK PLATING | | | | | | |
| TYPE | | MATERIAL CODE: FF0072 | | DRN. | TANVI | 08/03/07 | |
| THIRD ANGLE | | MANUFACTURER | | CHD. | AP | - | |
|  | | Fibre & Fibre Glass Products 250/7, MAGAZINE HOUSE G.I.D.C. MAKARPURA, VADODARA- 380010 | | APPD. | - | - | |
|  | | Fibre & Fibre Glass Products 250/7, MAGAZINE HOUSE G.I.D.C. MAKARPURA, VADODARA- 380010 | | DRAWING NO.: FFGP-007/07-08 | | Sheet Edition 1/1 0 | |
| | | | | | | REV 1 | |