

Signature Checked
Date
Revision note

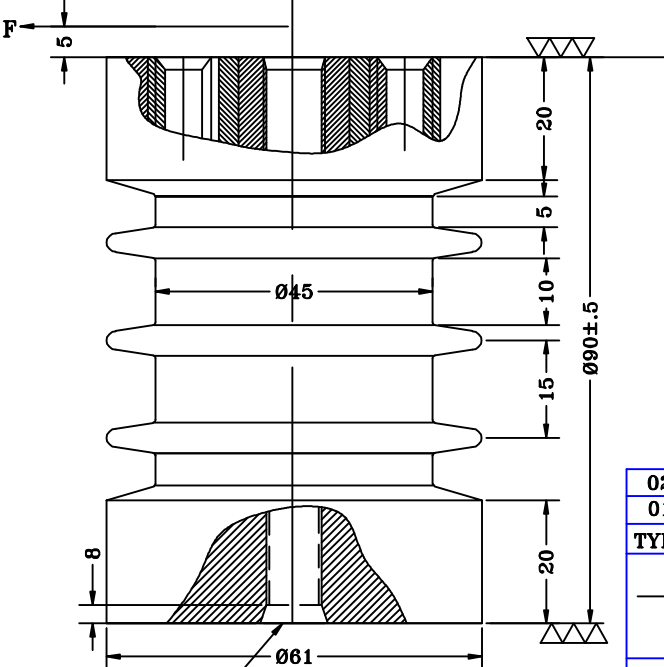

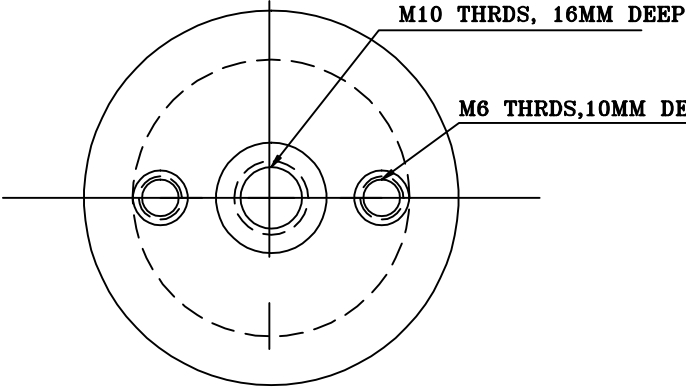

MECHANICAL SPECIFICATION IS: 9431-1979

- 1 BODY.....40mKg.
- 2 CANTILEVER FALINGS LOAD.....850Kgs.
- 3 COMPERSION FALLING LOAD.....8000Kgs.
- 4 TENSILE FALING LOAD.....1000Kgs.

ELECTRICAL SPECIFICATION IS: 9431-1979

- 1 RATED VOLTAGE.....6.6kv
- 2 IMPULSE WITHSTAND VOLTAGE.....50kv
- 3 ONE MINUTE WITH DRY WITHSTAND VOLATEGE.....27kv
- 4 CREEPAGE DISTANCE130mm

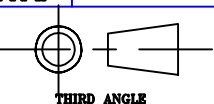
NOTES:-
* ALL DIMENTION ARE IN MM.
* COLOUR BRICK RED.

02	BRASS INSERTS		
01	M.S INSERT WITH WHITE ZINK PLATING		
TYPE	DISCRPTION		
 THIRD ANGLE	6.6kv	SIGN	DATE
	EPOXY RESINE CAST INSULATOR	DRN. TANVI	1/05/08
	ITEM CODE: FF0076	CHD. AP	-
		APPD.	-
	MANUFACTURER Fibre & Fibre Glass Products 250/7, MAGAZINE HOUSE G.I.D.C. MAKARPURA, VADODARA- 390010		DRAWING NO.: FFGP-0011/08-09
	Sheet	Edition	REV
	1/1	0	0