

Signature Checked

Date

Revision note:

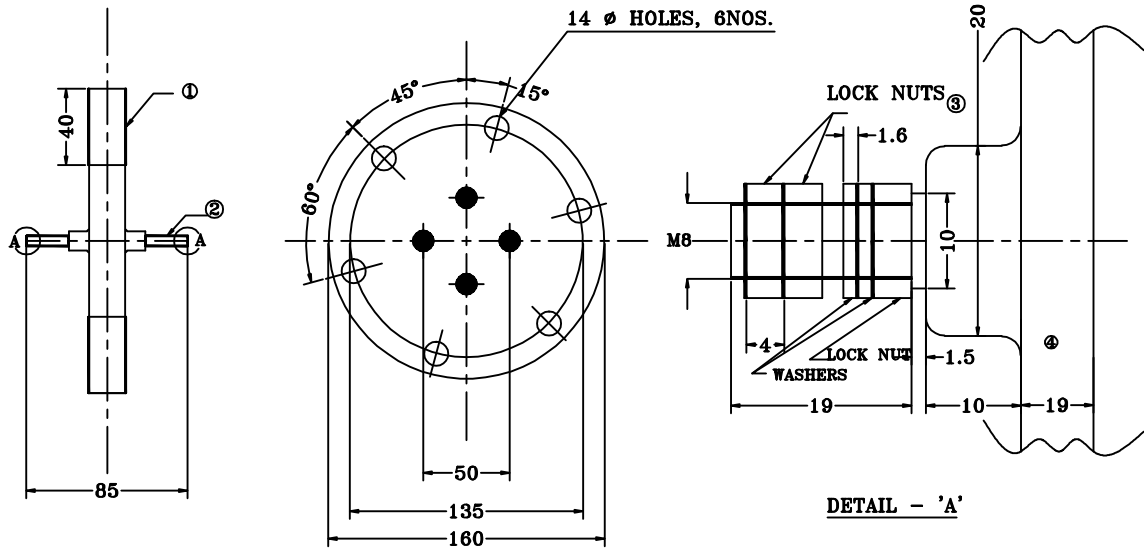

4 POINT TERMINAL PLATE

2	TERMINAL	10 Ø	BRASS ROD	4	BRASS WASHER	1.6	BRASS
1	TERMINAL BOARD	19	EPOXY RESIN	3	LOCK NUT	M8	BRASS
NO	PART NAME	THK.	MATERIAL	NO.	PART NAME	THK.	MATERIAL

SPECIFICATION:-

- MATERIAL - BORAD - VACAUM CAST EPOXY RESIN.**
 TERMINAL 10mm DIA BRASS ROD (CUZN 40 AS PER IS:4170) WITH M8 COARSE THREADS PER IS:4218 - 1967
 LOCK NUTS - BRASS LOCK NUTS CONFORMING TO IS: 1363-1967
 WASHERS - TYPE 'A' BRASS WASHERS CONFORMING IS: 2016-1967
- CURRENT RATING - 10A CONTINUOUS.**
- WITHSTAND VOLTAGE BETWEEN TERMINALS - 3.5Kv AC FOR 2 mln.**
- TERMINALS SHALL BE RIGIDLY FIXED TO THE TERMINAL BOARD SO THAT TERMINAL WILL NOT GET LOOSENED DAMAGED WHILE TIGHTENING NUT ON EITHER SIDE.**
- THE TERMINAL SHALL HAVE NO ADVERSE EFFECT ON TRANSFORMER OIL AT 110° AND SHALL BE IMPERVIOUS TO MOISTURE.**
- THE OIL TIGHTNESS AT 110° SHALL BE GURANTED UNDER A PRESSURE OF 2 kg/Cm² FOR 30mln**
- GASKET SURFACE SHELL BE EVEN SMOOTH(ROUGHNESS < 25 MICRONS) AND PARALLEL TO EACH OTHER.**
- THE TERMINAL BOARD SHALL BE SUITABLE FOR OPERATION AT TEMP. VARYING FROM 0 TO 110° AT FULL VACUUM.**
- WEIGHTS ARE EXCLUDING THAT OF NUTS & WASHERS.**

01	BRASS INSERTS										
TYPE	DISCIPTION										
<p>THIRD ANGLE</p>	4 POINT EPOXY TERMINAL PLATE		<table border="1"> <tr> <td>SIGN</td> <td>DATE</td> </tr> <tr> <td>DRN. TANVI</td> <td>25/05/09</td> </tr> <tr> <td>CHD. AP</td> <td>-</td> </tr> <tr> <td>APPD. -</td> <td>-</td> </tr> </table>	SIGN	DATE	DRN. TANVI	25/05/09	CHD. AP	-	APPD. -	-
	SIGN	DATE									
	DRN. TANVI	25/05/09									
CHD. AP	-										
APPD. -	-										
ITEM CODE: FF0083											
	MANUFACTURER Fibre & Fibre Glass Products 250/7, MAGAZINE HOUSE G.I.D.C. MAKARPURA, VADODARA- 390010		DRAWING NO.: FFGP-027/09-10								
	Sheet	Edition	REV								
	1/1	0	0								